

## TECHNICAL SPECIFICATION

### DUAL REMOTE CONTROL SWITCH RF



The remote devices for lighting control work through sending a frequent signal from the key to the receiver, which commands the connected to it lighting bodies. The installation of the key can be done in a standard round bracket as the advantage of this product is that there is no additional requirement for wiring from it towards the receiver. Thanks to this the product is widely used in premises with build in installations where there is no ability for adding the additional cable layouts and expenses for their building are reserved. The connection between the key and the receiver is through a frequent signal in the range- 315Mhz – 433.92Mhz.

## Technical data:

<b>Input voltage:</b>	110-220VAC
<b>Output power (per way):</b>	<ul style="list-style-type: none"><li>LED and ESL: 150W</li><li>Incandescent lamps: 400W</li></ul>
<b>Operating distance in open air (m):</b>	50m
<b>Battery:</b>	12V; 23a

## Dimensions:

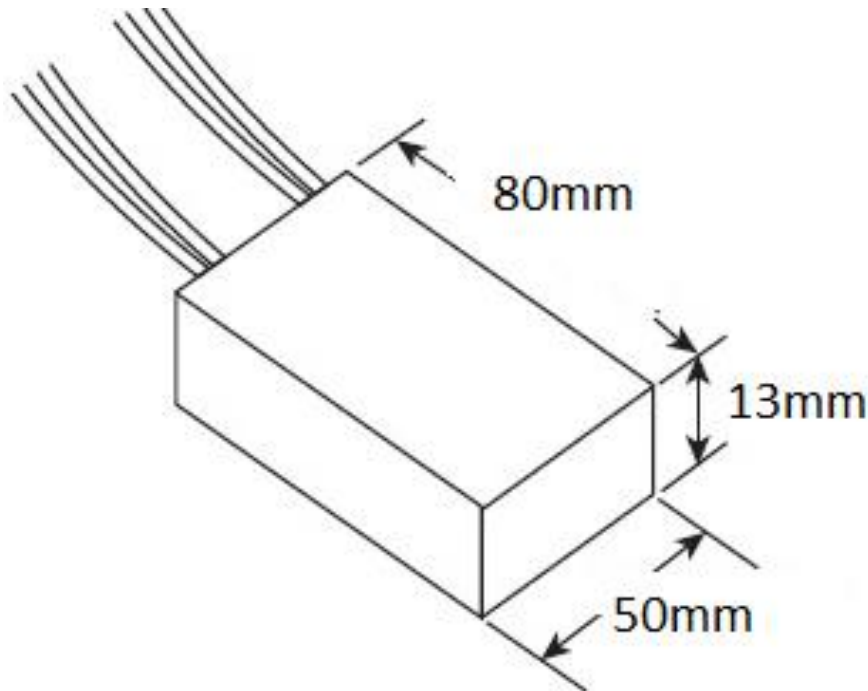

## Variants:

Catalogue number	Description	Voltage (V)	Operating distance in open air (m)	Output power (per way) ESL/ LED lamp	Incandescent lamp
<b>99104</b>	Two ways output power-2xE27	220V AC	50	150W	400W